

PR LIVE

EVENT PRODUCTION & HIRE

2016

An abstract graphic in the bottom right corner consisting of several overlapping, slanted rectangular bars in various shades of purple, creating a sense of depth and movement.

PEOPLE EQUIPMENT IDEAS

WELCOME TO OUR PRODUCT GUIDE

PR LIVE is a London based technical production house serving the live events and conference industry. We offer a large selection of the latest video, sound and lighting equipment both as dry hire and crewed.

This guide has been created to give you an insight into PR Live and our extensive stock. We have plenty more and are always investing in new technologies, if you don't see what you are looking for please call us in the office with your exact requirements.

RELIABLE CREATIVE AFFORDABLE

WHY CHOOSE US

WE LOVE what we do and understand what is required to get the job done. We have invested heavily in equipment and we charge fairly and openly.

Our staff are highly trained and we have in-house technical managers, technicians, production managers and designers to name but a few.



VIDEO

A world class range of high powered video projectors and a selection of LED screen products and media servers / control software in stock, ensures that PR Live stays at the forefront of this fast developing world.

Whether it is mapping a complete building with a spectacular large format projection show or providing live IMAG camera relay onscreen for conference delegates or creative video for a music show.

...We have the tools and the expertise.

PROJECTORS

PROJECTION SCREENS

LED WALL

D3 MEDIA SERVER

PLASMA & LCD SCREENS

VIDEO PROCESSING

PLAYBACK & RECORDING

SIGNAL DISTRIBUTION

CAMERAS

CONFERENCE AIDS

CHRISTIE

Christie Certified Partner



PROJECTORS

Christie Mirage WU20K-J Projector

- Technology:** 3DLP®
- Resolution:** 1920 x 1200 WUXGA
- Brightness:** 18,000 ANSI lumens
- Contrast:** 1600-2000:1 full field | 650:1 ANSI
- Illumination:** 3kW Xenon Bubble pre-aligned lamp module
- Interface:** Dual SD/HD SDI input card
Christie Twist compliant
- Height:** 16.5" (419mm)
- Width:** 24.5" (621mm)
- Depth:** 32" (815mm)
- Weight:** 160lbs (72.5kg) (without lens)
- Rigging:** Christie Mirage Flying Frame
- Lenses:** See next page for lenses available



Christie HD14K-M 1200 HD 3DLP projector

- Technology:** 3DLP®
- Resolution:** 1920 x 1200 HD
- Brightness:** 13,500 center lumens
12,000 ANSI lumens
13,500 ISO lumens
- Contrast:** Up to 2,500:1
- Illumination:** Dual 450W NSH
- Interface:** Dual SD/HD SDI input card
Christie Twist compliant
- Height:** 10.2" (259 mm)
- Width:** 19.7" (500 mm)
- Depth:** 22.1" (561 mm)
- Weight:** 55 lbs (25 kg)
- Rigging:** Stacking and Flying Frames
- Lenses:** See next page for lenses available



Christie ILS Lenses - suitable for Christie 20K and 14K Projectors

- Lenses:** Christie ILS Lens 0.73 SX / 0.67 HD
- Christie ILS Lens 1.2 SX / 1.1 HD
- Christie ILS Lens 1.25 - 1.6 SX / 1.16 - 1.49 HD
- Christie ILS Lens 1.5 - 2.0 SX / 1.4 - 1.8 HD
- Christie ILS Lens 2.0 - 2.8 SX / 1.8 - 2.6 HD
- Christie ILS Lens 2.8 - 4.5 SX / 2.6 - 4.1 HD
- Christie ILS Lens 4.5 - 7.5 SX / 4.1 - 6.9 HD
- Christie ILS Lens 7.5 - 11.25 SX / 6.9 - 10.4 HD

PROJECTORS



Christie DHD775-E Projector

- Technology:** 1-chip DLP
- Resolution:** HD 1920 x 1080
- Brightness:** 7,000 center lumens
- Contrast:** Up to 5000:1
- Illumination:** Dual 350W P-VIP
- Interface:** Dual Processor Warp Card
- Height:** 20.9" (532mm)
- Width:** 18.0" (456mm)
- Depth:** 8.5" (215mm)
- Weight:** 43.0 lbs (19.5kg)
- Rigging:** Includes Flying Frame
- Lenses:** Christie HD DLP 1.2 - 1.5:1 Short Zoom Lens
Christie HD DLP 1.5 - 2.0:1 Standard Lens
Christie HD DLP 2.0 - 4.0:1 Zoom Lens
Christie HD DLP 0.8:1 Fixed Lens



PROJECTION SCREENS

16:9 - Screens

- 16' x 9' Stumpfl Monoblox 32
- 12' x 6.9' Stumpfl Monoblox 32

Please Note: Flying rigging supplied on request.

4:3 - Screens

- 6' Pull-up Screen
- 6' x 4' Da-Lite Deluxe Fast-Fold Screen
- 8' x 6' Da-Lite Deluxe Fast-Fold Screen
- 10' x 7.6' Da-Lite Deluxe Fast-Fold Screen
- 12' x 9' Da-Lite Deluxe Fast-Fold Screen

Electric Drop-down Screens

- 8' Da-Lite Electric Screen
- 12' Da-Lite Electric Screen
- 16' Da-Lite Electric Screen

Please Note: Our Motorised Screens are Flying only.

LED WALL

'THE PICTURE PERFECT STAGE BACKDROP'

Absen A3 Pro 3.9mm LED Wall -

Our stock of 500 x 500mm panels are made from die-cast aluminium, weigh just 10Kgs and have a unique locking system allowing quick set up and de-rigging. Magnetic front modules are incredibly fast to remove / replace in case of maintenance – around five times quicker to deal with than screw-in modules.

The high brightness of 1200 NITs and a 3000:1 contrast with deep black levels the black-body SMD delivers crystal clear, consistent images, even when the brightness is reduced to 20% which is necessary in some applications, and an 140 degree wide viewing angle ensures high overall picture quality from any front-angle viewing position.

- Pixel Pitch:** 3.9 mm
- Brightness:** ≥ 1,200 nit
- Panel Dimensions:** 500 x 500 x 96 mm
- Panel Material:** Aluminium-alloy
- Weight:** 10 kg / panel
- Pixel configuration:** Black body SMD 3in1
- Module Dimensions:** 250 x 250 mm
- Pixel matrix per panel:** 128 x 128
- Pixel density:** 65536 pixels/sqm
- Includes:** Available with ground stack support or flying beam
Nova MCTRL 660 LED Controller
All cabling

Panel hire includes all processing and rigging



Traditionally a stage set would be built with timber and fabric...

LED is now more affordable and removes the hassle of a basic backdrop replacing it with a more creative, fun and lively approach! It can be set up in several different formats - as a single wall for conferences and for events and parties as columns, blocks or more.

It really is a blank canvas and can be anything you want it to be as the images above and below demonstrate.





MEDIA SERVER



d3 is a revolution in Media Server technology. It's reliability and hugely flexible toolset enable almost anything to be achieved when it comes to content playback. It will handle complex 3D projection mapping projects as easily as huge resolution LED canvases.

The d3 workflow is far more than just conventional playback. The software visualises screens and event spaces in a 3D environment enabling advanced, pixel-perfect simulations of stage designs and video playback, achieving detailed pre-visualisation and impressive camera fly-throughs.

However you wish to involve this technology, we can help, whether it be just the hardware, or the full workflow. Pre-programming, content sequencing, show operation. Our in-house specialists can devise a customised setup for your event, to get the maximum from this cutting edge tech for your budget. Let's get creative!

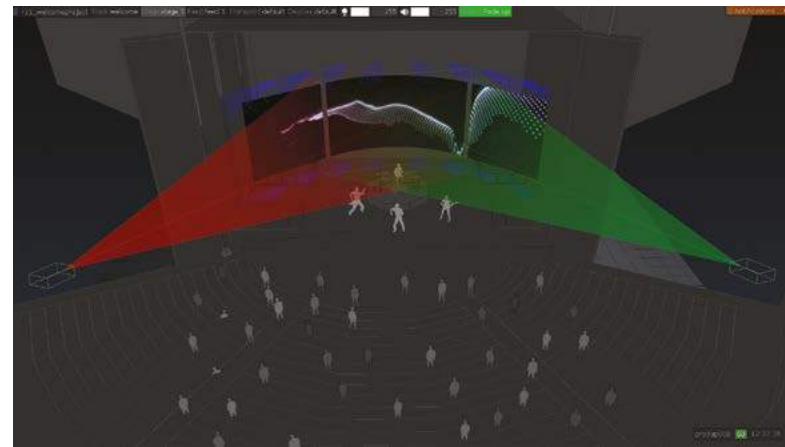
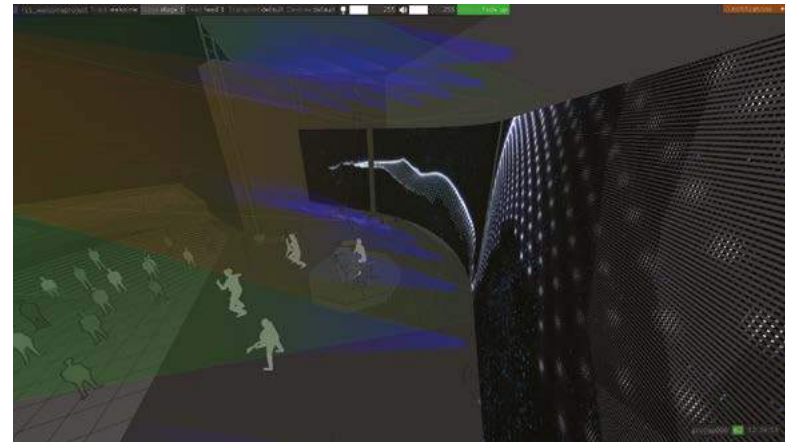
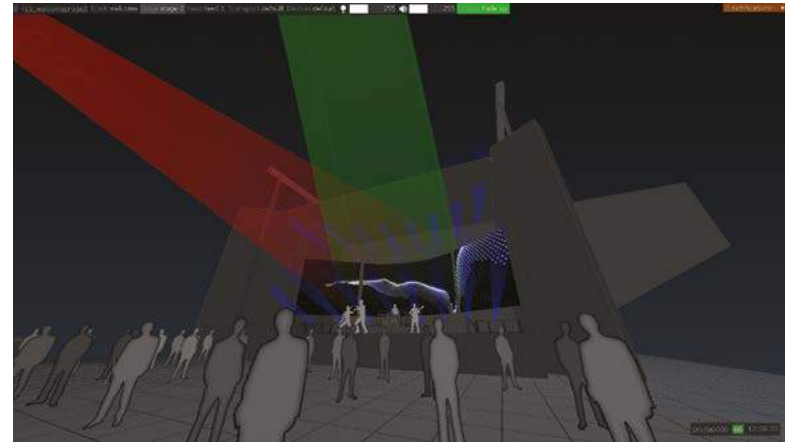

PLASMA & LCD SCREENS

LCD TVs

Samsung UE46EH5000	SMART TV
Samsung UE40EH	40" LCD Screen
Samsung UE46F6320	46" LED SMART TV

Professional Large Format Displays

Samsung MD55C	55" LCD Screen
Samsung MD65C	65" LCD Screen
Samsung DM75D	75" LCD Screen
Samsung ME95C (see next page)	95" LCD Screen

All LCD screens are 1080P and have the ability to play USB stick content

Plasma Screens

Panasonic TH42PF20ER	42" HD Plasma Screen
Panasonic TH50PF20ER	50" HD Plasma Screen
Panasonic TH65PF30ER	65" HD Plasma Screen
Panasonic TH85PF12ER	85" HD Plasma Screen
Aqualite outdoor IP66 rated	52" Plasma Screen OUTDOOR USE

All Plasma screens are 1080P with HD - SDi input and output

Stands

Unicol	Twin Pole - Flat Base
Unicol	Twin Pole - K Base with wheels
Parabella	Screen Stand - Silver

Please Note: All screens can be flown.

Samsung ME95C - 95" LCD Screen

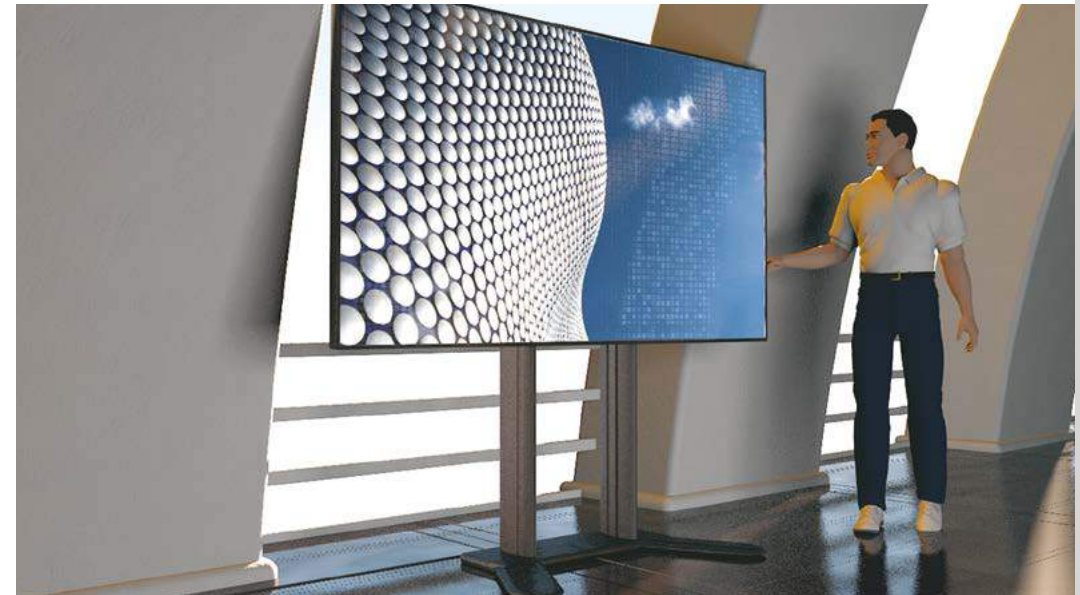

This is a high definition lightweight solution that can be easily lifted. Due to its incredible portability, the usage has rapidly expanded to include smaller meetings where it can be utilised instead of projectors. It is quicker and easier to set up, offers a brighter, crisper more high-impact picture and is an overall neater, cleaner solution that saves on room space and the amount of equipment required.

It can be used in portrait format as well as the more traditional landscape and is perfect for the fashion industry and all types of digital signage applications either as a stand-alone display or as integrated into a set, a backdrop or a graphic display.

Includes: Screen Lifter 75 stand and optional wallmount bracket.

PLASMA & LCD SCREENS

Screen Dimensions - including Bezel

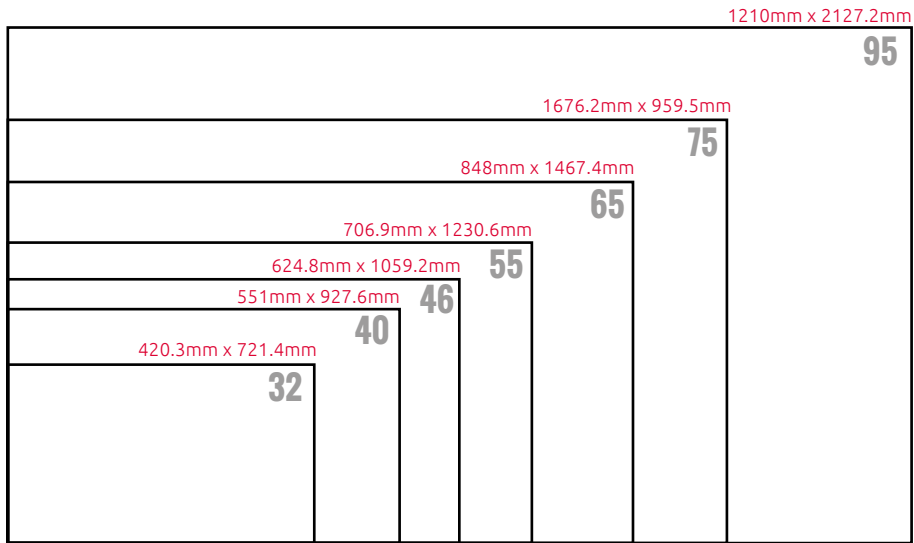

SAMSUNG H x W (mm)

32	420.3 x 721.4
40	551 x 927.6
46	624.8 x 1059.2
55	706.9 x 1230.6
65	848 x 1467.4
75	1676.2 x 959.5
95	1210 x 2127.2



PANASONIC H x W (mm)

32	510 x 860
42	610 x 1020
50	724 x 1210
65	925 x 1554
85	1473.2 x 2184.4

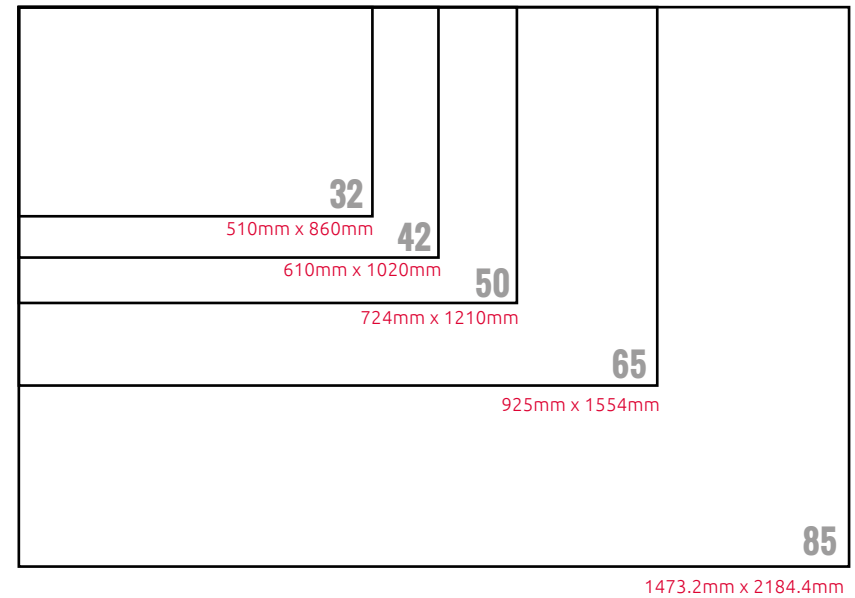

VIDEO PROCESSING

Seamless Switchers - Analog Way Ascender 32 (live core) - ASC3204

Powerful multi-screen Seamless Switcher based on Analog Way's new LiveCore™ platform, offering state-of-the-art processing, Soft Edge and 4K capabilities.

ASC3204 at a glance:

- 12 seamless inputs and 42 input plugs
- Independent Preview/Mosaic/Monitoring output
- Full live Preview of all sources (Preview/Mosaic/Monitoring)
- 4 true-seamless scaled layers + 1 native background layer per output
- Advanced Layer Management
- Rotation capability in output (step by 90 degrees)



Analog Way Ascender 32 (LiveCore)
front and rear view

12 seamless Inputs and 42 input sockets:

- 6 x HDMI/9 x DVI-I (3 DVI Dual Link included)
- 3 x DisplayPort (4-Lanes)
- 12 x 3G/HD/SD-SDI
- 12 x Universal Analog (6x HD15 & 6xDVI-A)

4 Outputs with 5 output sockets:

- Universal Analog (HD15 & DVI-A)
- DVI-I (DVI Dual-Link available on output #1 and #3)
- 3G/HD/SD-SDI
- Video Optical SFP module cage

To upgrade to 24 input and 08 output:

- Link two ascenders together using; analog way livecore link cable kit



Analog Way Ascender 32 (LiveCore)
two units linked together

Seamless Switchers - continued

Analog Way Pulse PLS300

Analog Way Di-ventix II HD with optional Axion 2 remote controller

Analog Way Pulse 2-3G PLS350-3G

RGB link VSP628 Pro HDCP compatible

Scalers and Matrices

Barco ImagePro - SDI

Matrox TripleHead2Go Digital

Lightware MX8x8DVI-Pro Matrix

RGB link VSP628 Pro HDCP compatible

Lightware MX16x16DVI-Plus Matrix

Datapath X4 Display Controller

Vision Mixers

Panasonic MX-70 Vision Mixer - SDI card

Panasonic AV-HS410EJ HD Vision Mixer
8 x SDI inputs, 1 x DVI
5 x SDI outputs, 1 x DVI
Integrated 7" multi mode colour LCD display



Panasonic AV-HS410EJ HD

PLAYBACK & RECORDING

Playback Pro	Comes with 13" solid state Apple MacBook.
Atomos Ronin	Digital file recorder with inbuilt preview monitor, broadcast solid state, twin rack mount as standard.
Atomos Samurai	Complete with blade pack. A portable touchscreen-operated HD recorder, monitor and playback device for video professionals. It captures pristine 10-bit 4:2:2 video and audio direct from any camera with HD/SD-SDI output. The Samurai consumes very little power, ensures long recording times and the efficient use of batteries.
Atomos Samurai	Sinch

SIGNAL DISTRIBUTION

Distribution Amplifiers

	VGA 4X4 Matrix	Kramer	VP5 – 5XL 1:5 VGA/UXGA
	1:2 HDMI DA	Kramer	VM4 – HDCP 1:4 DVI DA
	1:4 HDMI DA	Kramer	VM4 – HDCP XL 1:4 DVI DA
Extron	VGA DA P2DA 4Xi (4way)	Kramer	VM4 HD 1:4 39 HD-SDI
Extron	VGDA P2DA 6Xi	Kramer	SDI 1:10

CAT5 Interfaces

Lightware	DVI TPS extender for single CAT5/6 cable
Lightware	HDMI TPS extender for single CAT5/6 cable

Conversion Interfaces

HD Fury	Remote format converter	Ultra Studio 3D	Thunderbolt 2 x SDI in/out 2 x HDMI in/out Audion in/out balanced
Blackmagic	HDMI - SDI converter		
Blackmagic	SDI - HDMI converter		
Atomos	HD-SDI HDMI converter		

PRODUCTION & CONTENT

We create the content or work with yours making it look the best it can with our equipment. Event floor plans in CAD, 3D/2D visuals and style boards. We produce title graphics, motion graphics, key-note, video production, video editing, live visuals, graphic design and stage graphics.

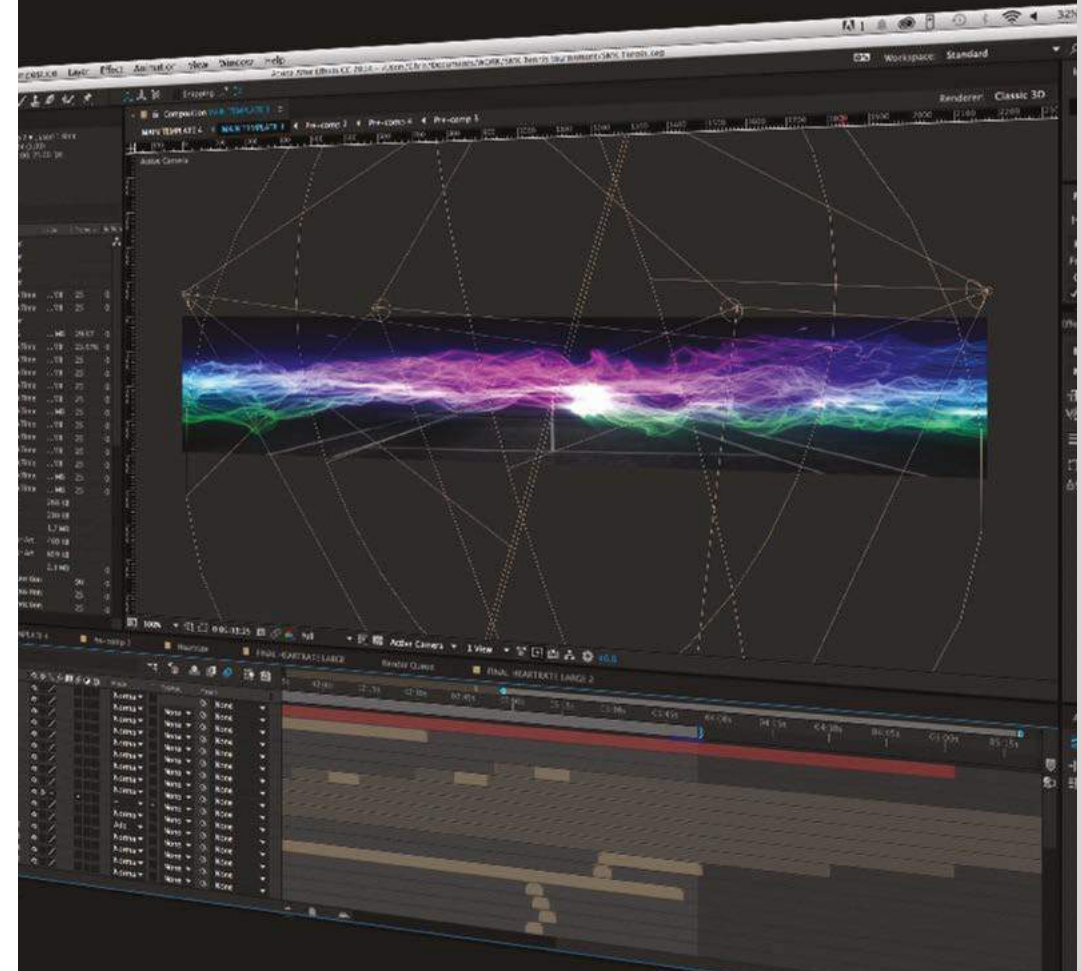

CAMERAS

Sony HXR-NX5E HD

Records quality 1920 x 1080 images at 24Mbps (50i or 25p), high performance G lens, AVCHD recording, audio input XLR and output.

Technology:	Three 1/3-inch Exmor CMOS sensors NXCAM AVCHD camcorder with GPS recording full HD / SD
Imaging Device:	3-chip 1/3-inch type Exmor CMOS
Focal Length:	f = 4.1 to 82.0 mm (equivalent to f = 29.5 to 590 mm at 16:9 mode, f = 36.1 to 722 mm at 4:3 mode on 35 mm lens)
Recording Format:	HD Video MPEG-4 AVC/H.264 (AVCHD) SD Video MPEG-2 PS
Recording frame Weight:	/50i, AVCHD HQ (9Mbps) 1440x1080/50i, AVCHD LP (5Mbps) 1440x1080/50i, AVCHD FX (24Mbps) 1920x1080/25p, AVCHD FH (17Mbps) 1920x1080/25p, AVCHD FX (24Mbps) 1280x720/50p, AVCHD FH (17Mbps) 1280x720/50p, MPEG SD HQ (9Mbps) 720x576/50i, MPEG SD HQ (9Mbps) 720x576/50i (25p Scan)
Media:	Memory stick PRO Duo(Mark2), Memory Stick PRO-HG Duo, Memory Stick PRO-HG Duo HX, SDHC Card
SDI output:	BNC (x 1), HD-SDI/SD-SDI selectable

Sony PMW-EX3 HD

Technology:	Three 1/2-inch type Exmor CMOS sensors XDCAM EX camcorder with interchangeable lens system recording full HD / SD
Recording/Playback Time (MPEG HD):	HQ Mode: Approx. 100 min with SBP-32 (32 GB) memory card Approx. 50 min with SBP-16 (16 GB) memory card Approx. 25 min with SBP-8 (8 GB) memory card SP Mode: Approx. 140 min with SBP-32 (32 GB) memory card Approx. 70 min with SBP-16 (16 GB) memory card Approx. 35 min with SBP-8 (8 GB) memory card
Media:	SxSPRO, 1920 X 1080 HD recording, semi shoulder design, zoom ratio:14x optical, audio input XLR and output video HD-SDI/SDI selectable
SDI Output:	BNC (x1), HD-SDI/SD-SDI selectable
Effective Picture Elements:	1920 (H) x 1080 (V)



Sony HXR-NX5E HD



Sony PMW-EX3 HD

Please Note: Medium and heavy duty camera tripods available. We can supply camera risers.

CAMERAS

Sony BRC700 - 2 Way Robotic Camera System



All-in-one, robotic colour video camera for remote shooting applications. Superb picture quality - three 1.07 megapixel CCDs High-performance Pan/Tilt /Zoom mechanism RS-232C/RS-422 remote control (VISCA protocol) Versatile video outputs.

Flexible installation - ceiling mount or flat surface

Sixteen presets

Multi-function IR remote commander unit

Easy-to-use and ergonomically designed remote control unit (RM-BR300)

SDi output

Small Cameras

Marshall mini cam

PRO-XW - HDU04/04J HD, SDI
Wireless transmitter and receiver

Go Pro Hero 4



Accessories

Manfrotto magic arms

Manfrotto camera truss clamp

Blondie 3 way lighting kit

Carbon Fibre boom arm – length

Sennheiser zoom boom microphone

Miller 850 tripod

Medium and heavy duty camera tripods available

CONFERENCE AIDS & COMFORT MONITORS

Conference Aids

Auto-Cue Prompting system

Interspace Industries Microcue 2 Dual USB Control System

Countdown Display Kit

Interspace Industries Count Down Touch C/W Big Display

Interspace Industries Microcue 2 Kit

Interspace Industries Traffic Light system

Interspace Industries Mastercue V4 Cue System

Interspace Industries Mastercue V5 Cue System

Comfort Monitors

10" - for lectern or top table

24" - for small conference

32" – 55" - for larger stages and presentations

These can be supplied with discreet floor hide.





SOUND

All scenarios, from spoken word to a full orchestra or a high energy rock 'n' roll band, in any space from the smallest meeting room to the largest auditorium or arena, the sound will be of the highest quality and appropriate for the application.

SOUND

SPEAKERS & AMPLIFIERS

CONSOLES

MICROPHONES

DJ EQUIPMENT

COMMUNICATIONS & SOUND ACCESSORIES



SPEAKERS & AMPLIFIERS

Speakers



d&b B2 Sub Speaker



d&b B4 Sub Speaker



d&b E3 Speaker



d&b E5 Speaker



d&b E9 Speaker



d&b E12 Sub Speaker



d&b M4 Monitor



d&b T Sub Speaker



d&b T10 Speaker



d&b Q7 Speaker



d&b Q Sub Speaker

	Flying Weight	Black Boxes	White Boxes
d&b B2 Sub Speaker	N/A	✓	
d&b B4 Sub Speaker	N/A	✓	✓
d&b E3 Speaker	9kg	✓	
d&b E5 Speaker	3kg	✓	✓
d&b E9 Speaker	32.2kg	✓	
d&b E12 Sub Speaker	22kg	✓	✓
d&b M4 Monitor	N/A	✓	
d&b T Sub Speaker	18.1kg	✓	
d&b T10 Speaker	17kg	✓	✓
d&b Q7 Speaker	30kg	✓	
d&b Q Sub Speaker	42kg	✓	

Speaker Rigging For d&b T Series

Z5373	Cluster bracket	Z5147	Rota clamp
Z5370	T line array flying frame	Z5375	T base plate ground stacked array

Speaker Stands

- K&M** Round base stands in black and white
- K&M** Tripod, winch up, heavy duty stand in black only
- Bespoke** Low level and discreet stands in black, white and stainless steel

Active Speakers

- Yamaha MOS 101
- 10" Active Monitor

Amplifiers

d&b D6 Amplifier

- Inputs 2 x F-XLR with Loop through and link switch
- Outputs 4 x NL4 Speakon (A+B)

d&b D12 Amplifier

- Inputs 2 x F-XLR with Loop through and link switch
- Outputs 4 x NL4 Speakon (A+B)

d&b E-Pac Amplifier

- Inputs 1 x Analogue F-XLR + Loop Through
- Outputs 1 x F-XLR



d&b D6 Amplifier



d&b D12 Amplifier

d&b E-Pac Amplifier





Wireless Sennheiser Speaker LSP500



Completely wireless PA system. Perfect for a large variety of situations; for example, outdoor events or where an instant install is required. Up to 3 wireless mic links, bluetooth music streaming, built in USB player/recorder. Dual batteries are hot-swappable even during live operation. iPad control available via app.

Dimensions: 290 x 550 x 320 mm (WxHxD)

Weight: 13.6 kg (30 lb. approx.) w/o wireless receivers

CONSOLES

Digital Sound Desk _ Yamaha QL1

QL series consoles offer all-in-one mixing, processing, and routing capability for small to medium scale live sound, corporate speech events, installations, and much more.

Features:

- 300 Scene Memories
- Dante Feature
- Versatile Input and Output Delays
- Ample EQ and Dynamics Processing
- 16 DCA Groups
- 8 Mute Groups
- 12 User Defined Keys
- Multiple User Key Sets
- 5-In/5-Out GPI Interface
- Power requirements: 100-240V 50/60Hz
- Power consumption: 135w
- Dimensions: W: 468mm (18.4in) H: 272mm (10.7in) D: 562mm (22.1in)
- Net weight: 14.7kg(32.4lb)
- Compatible with the Rio Rack 1608D, available for hire



Digital Sound Desk _ Yamaha LS9- 32 and LS9-16

Features:

- 16 top-performance recallable head amplifiers deliver mic and line sources with stunning presence and realism
- An additional 16 channels available via the Mini-YGDAI expansion slot (external preamps and optional Mini-YGDAI interface cards needed)
- 4 stereo input channels
- An extensive range of channel functions
- Versatile bus architecture with comprehensive digital patching capability
- Virtual GEQ and effect rack
- Built-in USB Memory Recorder/Player
- Full-console scene Store and Recall
- Ready to use out of the box with pre-patched effects and pre-fader aux mixes for monitor sends
- Compact size: 19" x 8.66" x 19.75" (480 x 220 x 500mm), 26.4 lbs (12 kg)



Rio Rack 1608-D

- Dante network protocol contributes to greater system scalability and flexibility
- Support for CL series consoles as well as other Dante based systems
- Automatic digital-stage compensation for analog gain changes (CL series only)
- Four models flexibly accommodate any system requirements



Yamaha Digital Multi Core SB168 - ES

- Ethersound Protocol
- Audio over cat5 for 100m
- Daisy chain connections through MY16-ES64 and MY16- EX mini-YGDAI cards
- SB168-ES head amp remote function from the mixing console to adjust mic gain levels so that they match specific sound scenes



Digital Sound Desk _ Digico SD9

Features:

- 48 Flexi Channels (Equivalent to 96 channels of DSP)
- 47 Busses made up of 16 Flexi Busses plus L/R
- L/C/R Master
- 2 Solo Busses
- 12x8 Matrix 8 DiGiTuBes available
- 8 Dynamic Equalizers
- 8 Multiband Compressors
- 8 Digital Effects
- 16 x 31 Band Graphic EQ
- Multi Channel Folding Reorder Busses
- Two D-Rack Stage Boxes
- Two Digital Snakes



Digital Sound Desk _ Digico D-Rack 32-8

Features:

- 32 microphone inputs
- 8 line outputs and 8 modular outputs that can be selected as either analogue or AES, providing a maximum capacity of 32 ins and 16 outs
- With a digital CAT5E cable to connect to the console work surface, the hum and noise of analogue multicores are eliminated
- Can now also run @96kHz on CAT5E with 28 Mic inputs and up to 16 outputs
- The D-Rack also offers the options of Rack mount ears, an extra PSU (for redundancy) and fibre optic connection



Analog Sound Desks

Yamaha 12Ch

Midas Venice 16:4:2 (pictured)

A&H Mix-Wizard 14:4:2



MICROPHONES

Wireless Microphones

Sennheiser EM2050 Dual Channel Kit SKM2000 Handheld
SK2000 lapel with ME104
optional SKP2000 plug in transmitter module - turn
lectern microphones into wireless

Sennheiser G3 Single Channel Kit G3 Handheld
G3 lapel with ME104

Sennheiser Antenna Kits Omni Directional A1031-U
Directional A2003-UHF

Optional on all of the above: DPA 4088 Headset microphone

Shure ULX-D is a premium digital microphone with advanced encryption allows completely privacy for high security applications. DANTE compatible.

We can supply with the following interchangeable cartridges:

B58 • B87A • B87C • SM58



In Ear Monitors

Sennheiser SR2050 Dual Channel Kit 2 x EK2000 IEM
Antenna

Sennheiser G3 Single Channel Kit

Lectern and Table Top

Audio – Technica ES915 Lectern Kit

Shure MX412 12" Gooseneck

Shure MX418 18" Gooseneck

Stands

Desk Top Microphone Stand Adjustable

Sraight Round base

Long boom

Short boom

BRAND	MODEL	DYNAMIC	CONDENSER	VOCAL	DRUMS	INSTRUMENT	LECTERN	BOUNDARY	SHOTGUN
Shure	SM 58	✓		✓	✓				
	SM 57	✓		✓	✓	✓			
	Beta 58A	✓		✓	✓				
	Beta 57A	✓		✓		✓			
	Beta 52A	✓							
	PG 52	✓		✓					
	PG 56	✓							
	PG 81		✓		✓	✓			
	Beta 91A		✓		✓			✓	
	Beta 98 HC		✓		✓				
	Beta A 98 D		✓		✓	✓			
	MX 412		✓					✓	
	MX 418		✓					✓	
Sennheiser	E 904	✓			✓	✓			
	E 906	✓				✓			
	E 914		✓		✓	✓			
	E 608		✓			✓			
	E 835	✓		✓					
	E 8155	✓		✓					
	MKH 60		✓						✓
AKG	D 112	✓			✓				
	C 547 BL		✓					✓	
	C 451		✓		✓	✓			
	C 414		✓		✓	✓			
	CK 91		✓		✓	✓			
Audio Technica	ES 915		✓				✓		
	AT859QLX		✓				✓		



DJ EQUIPMENT

Decks

Pioneer XDJ - RX

Pioneer CDJ2000 Nexus

Pioneer DJM-900 Nexus

Pioneer CDJ-2000

Pioneer DJM-800

Technics SL1210 Turntables



Pioneer XDJ - RX



Pioneer DJM-900 Nexus



Technics SL1210 Turntables

Accessories

CDJ Raised platform

M4 monitor

D12 amplifier

See **Set & Staging** for DJ Booths

COMMUNICATIONS & SOUND ACCESSORIES

Show Comms

Wireless:	HME DX200	Wireless 6-Way Talkback System
Wired:	RTS Telex PS20	Single headset Talkback kit. Includes Beyer DT109 headset and BP325 twin channel controller.

Our wired and wireless comms can be linked together.

2 Way Radios

Motorola GP344 Battery - supplied in 6 way kits with charger. We can supply with in ear adaptors, D-shell and belt clip with pouch or straps.

Conference

Induction Loop Kit - to support hearing aids

Sonifex Telephone Balancing Unit - allowing your telephone call/conference call to be heard through the sound system. An analog line must be provided.

Polycom Conference Phone

Recording & Playback

Instant replay - perfect for award show stings and walk ups. Comes pre loaded with a selection of pre recorded clips.

Tascam CD/recorder

Tascam CD player

Marantz compact flash recorder

Zoom compact flash recorder



LIGHTING

We can offer imaginative and creative lighting solutions using the best and most energy efficient solutions and equipment currently available.

An extensive stock of moving lights and LED sources from the major brands, plus 'conventionals', effects fixtures and a massive inventory of wireless LED luminaires ideal for all types of events. Great lighting can enhance and transform any environment for an event.

DESKS

DIMMERS

LED

MOVING FIXTURES

DECOR & GENERIC

EMERGENCY AND ACCESS LIGHTING

LIGHTING



DESKS

Chamsys Magic Q MQ100 Lighting Desk



MagicQ MQ100 Pro 2014 provides an immensely powerful control console - 64 universes direct via ArtNet, ACN or Pathport. All 64 universes are processed onboard - no extra processing nodes required. 32768 channels in a compact package, proven to run at full speed with all channels fully patched, there really is no similarly packaged console that can sustain this performance.

MagicQ software features easy patching from a library of 9000 fixture personalities, simple attribute selection and programming, flexible live lighting control including a powerful inbuilt Pixel Mapper.

Features:

- 64 Universes
- 10 Full Playbacks (202 virtual)
- In-built Ethernet Switch
- In-built UPS
- Solid State Drive
- Complete Console Solution
- MIDI, SMPTE, Audio ports
- Designed and manufactured in the UK
- Tracking / non-tracking option
- Fixture, FX and gel library
- In-built fixture editor
- In-built media engine
- LED pixel mapping
- Fixture morphing and cloning
- Rainbow colour picker (CMY, RGB, HSI)
- Individual fade times on any channel
- Easy fanning of parameters and times
- Configurable faders - HTP, LTP, speed, size, masters
- Theatre mark cues, split fades and inhibit masters
- Client/server network architecture
- Multiple console playback tracking
- Remote console control
- Visualiser support (including patch transfer)
- Architectural zoning and day/date support
- In-built UPS (~15 mins)
- Handy armrest storage compartment
- Keyboard, mouse and Dust Cover
- MIDI & SMPTE built in
- Audio Input

We also stock the Chamsy MQ60 Lighting Desk and for an even smaller show the Chamsys Dongle.

Additional Desks

Avolites	Pearl Tiger
Chamsys	Magic Q MQ60
Chamsys	Magic Q Dongle
Chamsys	Magic Q Execute Wing
Pulse	6 Channel Controller
ETC	Smartfade 24/48
Chroma-Q	DMX Buffer Box - 4 Way
Proplex	2 in 8 Out DMX Buffer Box

Accessories

Chamsys	Magic Q Execute wing
Chroma-Q	DMX Buffer Box 4-way
Proplex	2 in 8 out DMX Buffer Box
Wireless Solutions	Black box F-1 G4S MK2

DIMMERS

Avolites ART2000 T2

Providing a complete solution to Dimming, Moving Light Power and Data distribution. No need to have separate mains distribution or DMX splitters making set up times faster and lowering the number of individual components needed to put a show together.

The ART 2000 controls up to 24 individual channels using four plug in modules of 12 channels each.

The available modules types are:

16amp 12 channel continuously rated dimming module with 250uS rise time and local controls

16amp 12 channel switch module for powering moving lights or other equipment.

16amp 12 Channel Contactor module, allowing remote switching of ballasted fixtures

10 Socapex or 8 Harting Multicore outlet connectors ensure that cabling will be as simple and reliable as possible. Each channel of each Multicore output connector can be patched to any channel using the top Hot-Patch. The Hot-Patch incorporates a battery operated lamp test indicator making faults easy to find when the same circuit powers more than one fixture, even when there is no mains available.

Other features include full DMX patch and merge (2 DMX lines), dimmer curve and limit selection per channel, power OK indicators. Analog Volt and Amp metering or optional Digital metering. Single pole connector or P17 CeeNorm mains input and loop out options with RCB or optional ELDC selectable earth leakage protection.

Additional Dimmers

Alpha	Pack 2 Dimmer
Any Pro	2 x 16A Channel 16A
Any Pro	1 x 10A Channel 13A
ZERO88	6 Channel DMX controller
ZERO88	12 Channel Remote
ZERO88	Rack 6 Dimmer

LED LIGHTING

EZ Pin - Wireless pinspot light

Features:

- Battery powered and compact LED, perfect for lighting key features, centerpieces, art, cakes and signage, etc
- Magnetic Base affixes to most metal surfaces, eliminating the need for clamps
- Scissor clip with eye loop easily attaches to drop ceiling supports for speedy set up and de rig.
- Remote control
- Versatile looks, to include warm white, red, green, blue and yellow.
- Maximum battery life 6 hours
- Recharge time 3 hours

Weight: 0.3kg

Dimensions: 191 x 90 x 55mm



Core Colourpoint Battery uplighter

Features:

- Very fast setup and get-out for events
- Outdoor rated IP65
- No mains or data connection wires for a safer environment
- Will light 2-3 storeys using 4 x high brightness LED quad chips
- Even colour mixing & easy white pastel shades using 4-colour Cree LEDs(RGB+W)
- Recharge under 4 hours & very lightweight 4.4Kg using Li-Ion Battery
- Wireless controlled from Point20 Uplight - Wireless Solutions DMX
- Battery life exceeding 8-10 hours on maximum output dual colour or cycle
- Attractive 'CORE Family' cylinder shape with optional removable stainless shroud
- Designed and manufactured in the UK

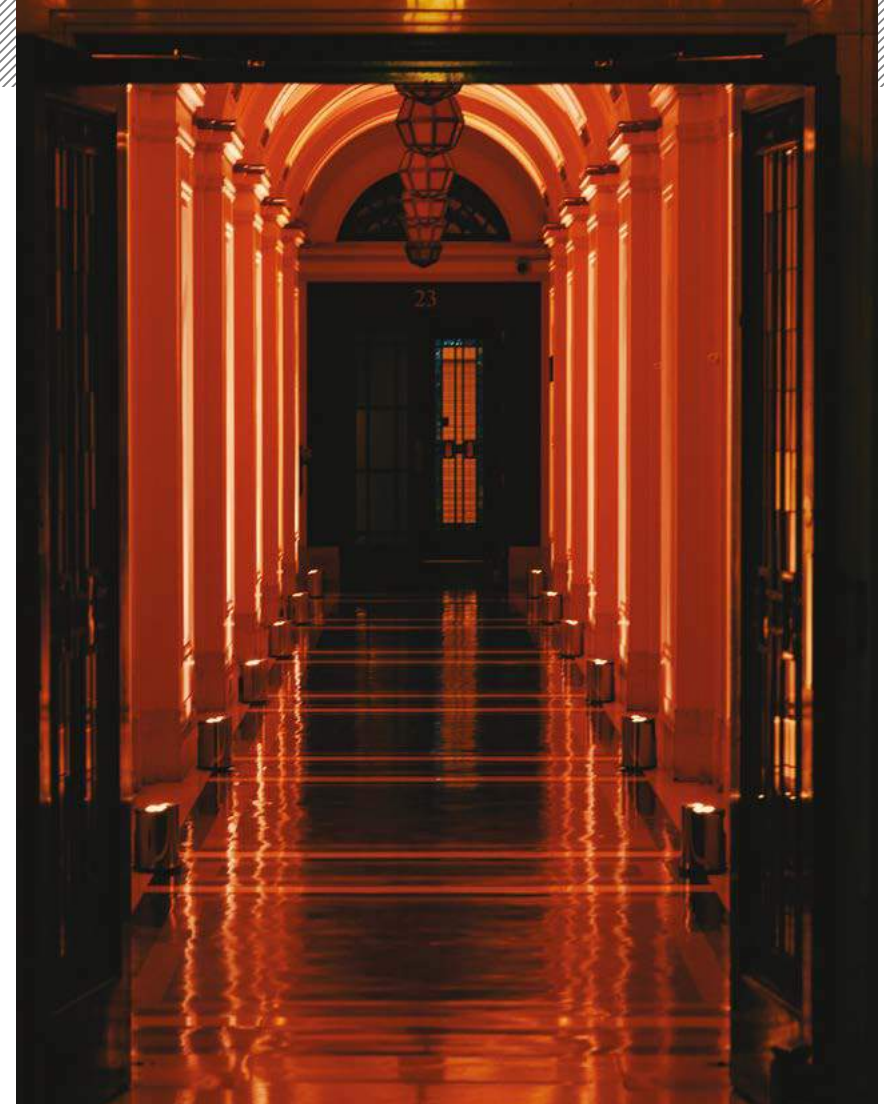

Other LED lighting

Core	Point30 Outdoor Battery Uplighter
Thomas	Pixel Par 90 LED Light
Milltec MTC	LED Batten 2 - 1 metre

LED - MOVING FIXTURES



Clay Paky A.leda Wash K10
- C61405

Clay Paky Alpha Spot HPE 700
- C61355

Robe Robin® LED Beam 100



GENERIC & DECOR LIGHTS

Generic Lights

- Source 4 Profile 750W
- Source 4 Junior Zoom - black
- Source 4 Junior Zoom - white
- Fresnel Acclaim in black and white
- Pinspots - Bank of 4 in black and white
- Par 16 Birdie
- Sunstrip Active 10 Lamp DMX batten



Decor Lights

Festoon
We stock three type in a selection of lengths 7m, 10m and 100m.

- Bulb type:**
- Coloured
 - Carbon Filament
 - Plain

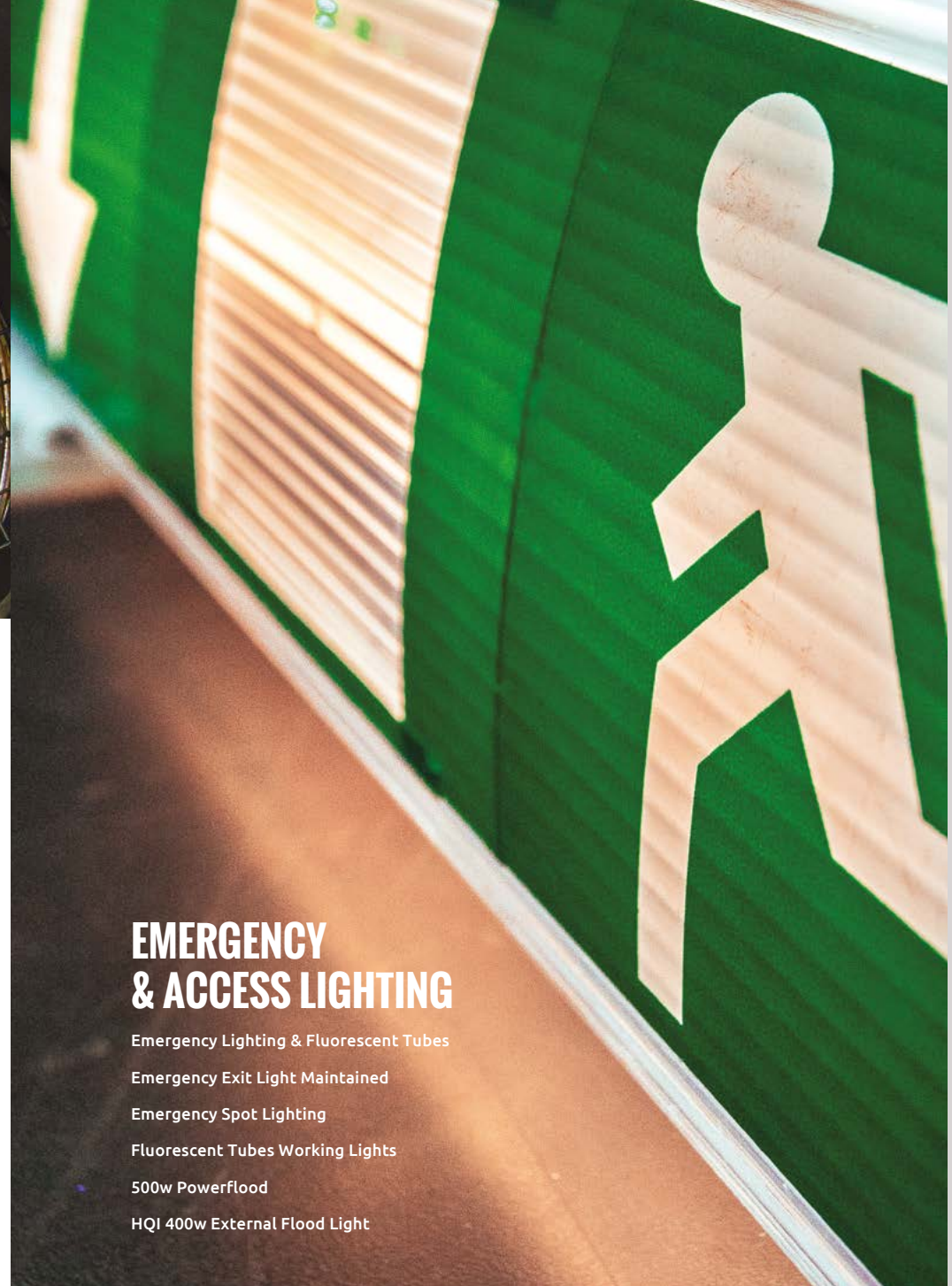

EMERGENCY & ACCESS LIGHTING

- Emergency Lighting & Fluorescent Tubes
- Emergency Exit Light Maintained
- Emergency Spot Lighting
- Fluorescent Tubes Working Lights
- 500w Powerflood
- HQI 400w External Flood Light



POWER

We have an extensive power distribution (PD) inventory including sub-distro, safety breakers, cabling, RCD's and break-outs.

CABLES
DISTRIBUTION
CONVERTERS



POWER

HEAVY MAINS

Cables

SINGLE PHASE CABLE

- 13A Extensions 2-way - 5, 10M
- 13A Extensions 4-way - 2M
- 16A Extensions - 5, 10, 20M
- 32A Extensions - 2, 5, 10, 20M
- 63A Extensions - 2, 5, 10, 20M

THREE PHASE CABLE

- 16A Extensions - 5 M
- 32A Extensions - 2, 5, 10, 20M
- 63A Extensions - 2, 5, 10, 20M
- 125A Extensions - 2, 5, 10, 20M
- 125A to Powerlock



Distribution & Converters

Incomer	63A 3Ø
Outgoing	1 x 63A 3Ø 12 x 16A 1Ø 2 x Socapex Female
Circuit Protection	12 x 16A MCB
Weight (Kg)	18
Dimensions (mm)	600 x 500 x 300
IP Rating	IP44

Incomer	63A 1Ø
Outgoing	3 x 32A 1Ø
Circuit Protection	63A RCCD 30mA, 3 x 32A MCB
Weight (Kg)	18
Dimensions (mm)	400 x 100 x 100
IP Rating	IP44

Incomer	63A 3Ø
Outgoing	1 x 63A 1Ø 2 x 32A 1Ø 2 x 16A 1Ø
Circuit Protection	Multi Meter. 63A 3P RCCB 30mA, 63A 1P MCB, 2 x 16A RCBO 30mA, 2 x 32A RCBO 30mA
Weight (Kg)	20
Dimensions (mm)	400 x 300 x 300
IP Rating	IP44

Incomer	16A 1Ø
Outgoing	1 x 16A 1Ø 6 x 13A Socket Outlets
Circuit Protection	N/A
Weight (Kg)	10
Dimensions	150 x 400 x 100
IP Rating	IP20

Incomer	63A 3Ø
Outgoing	3x Socapex Female
Circuit Protection	18 x 16A MCB
Weight (Kg)	18
Dimensions (mm)	600 x 300 x 310
IP Rating	IP44

Incomer	32A 1Ø
Outgoing	4 x 16A 1Ø
Circuit Protection	32A RCCD 30mA 4 x 16A MCB
Weight (Kg)	8
Dimensions (mm)	400 x 150 x 200
IP Rating	IP44

Incomer	63A 1Ø
Outgoing	7 x 16A 1Ø 3 x 32A 1Ø
Circuit Protection	63A 1P RCCB 30mA, 5 3 x 32A MCB, 8 x 16A MCB
Weight (Kg)	20
Dimensions (mm)	320 x 450 x 450
IP Rating	IP44

Incomer	16A 1Ø
Outgoing	1 x 16A 1Ø 14 x 13A Socket Outlets
Circuit Protection	16A RCBO 30mA
Weight (Kg)	12
Dimensions (mm)	200 x 200 x 400
IP Rating	IP20

Incomer	32A 3Ø
Outgoing	6 x 16A 1Ø 2 x 32A 1Ø
Circuit Protection	32A 3P RCB 30mA 6 x 16A MCB
Weight (Kg)	15
Dimensions (mm)	200 x 200 x 400
IP Rating	IP44

Incomer	32A 3Ø
Outgoing	3 x 32A 1Ø
Circuit Protection	N/A
Weight (Kg)	0.5
Dimensions (mm)	200 x 200 x 200
IP Rating	IP44

We stock a large range of adaptors and converters this is just an example selection, please call us with your requirements.

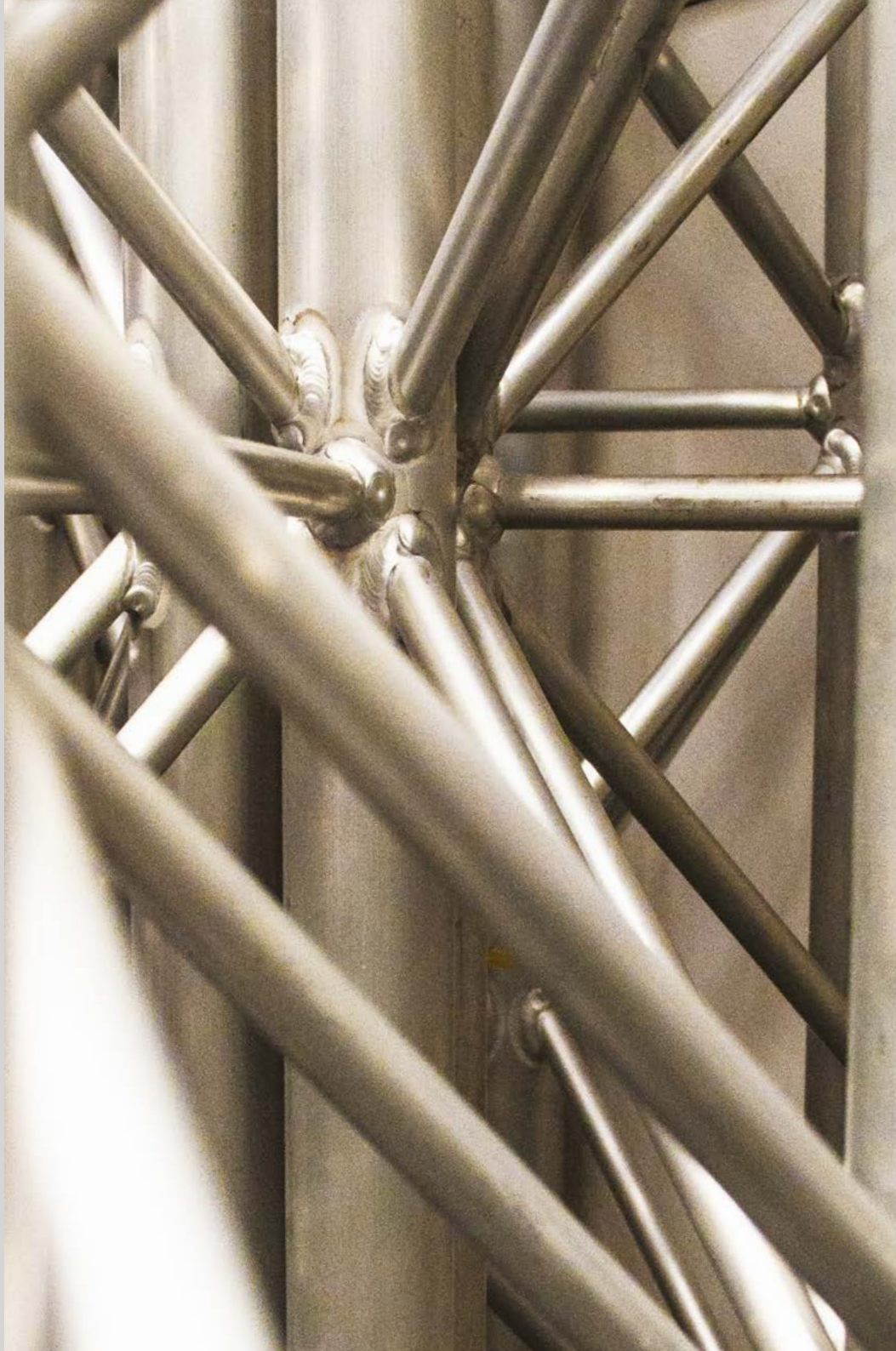

RIGGING

A large range of truss, motors and associated rigging accessories helps facilitate the most flexible, adaptable and safe installations for our sound, lighting, video and staging infrastructures in all venues and event spaces.

Our skilled rigging crews are renowned for their lateral thinking, so any potential challenges or more unusual situations can be met with effective solutions and good working practices.

TRUSS
ACCESS EQUIPMENT



RIGGING

TRUSS

Prolyte H30V-L25 0.25m



Prolyte H30V-L100 1m



Prolyte H30V-L150 1.5m



Prolyte H30V-L200 2m



Prolyte H30V-L300 3m



Prolyte H30V C003 2-way 90 deg corner



Prolyte H30V C012 3-way corner



Prolyte H30V C017 3-way T-Piece



Prolyte H30V C020 4-way T-Section



Prolyte H30V C024 5-way corner

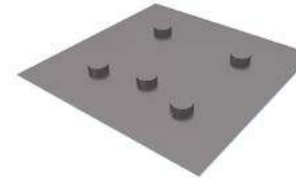

Prolyte H30V heavy duty base plate



Prolyte H30V small base plate

ACCESS EQUIPMENT

- Access ramps
- Tower Lift Max - 5.4m 220kg
- Cable Ramp - 80cm
- Zarges 6 Rung Ladder
- Zarges 8 Rung Ladder
- Zarges 10 Rung Ladder
- Zarges 12 Rung Ladder
- Zarges 14 Rung Ladder



SET & STAGING

Any set requirement however large or small, straightforward or sophisticated can be designed and created from inception as a bespoke project. PR Live also has a range of standard flexible set and staging elements available for events.

We also work with the client's existing designs and concepts, and will realise, construct and install these to the highest standards.

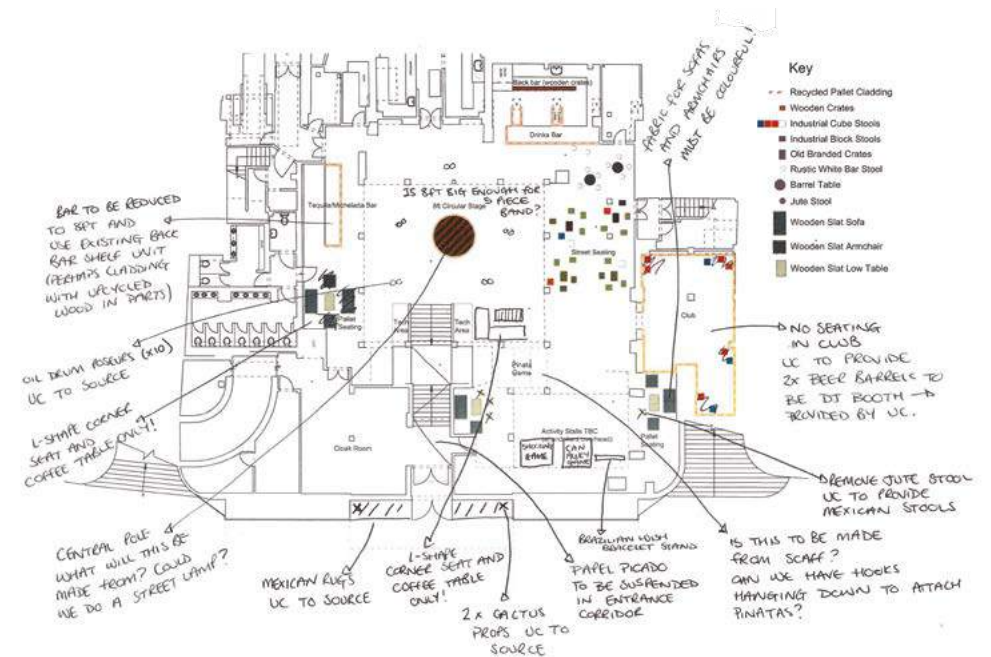

STAGING

Litedeck

- 8' x 4' Stage Section
- 6' x 4' Stage Section
- 4' x 1' Stage Section
- 4' x 2' Stage Section
- 4' x 4' Stage Section
- 4' x 4' Qtr Circle Stage Section
- 6' x 2' Stage Section
- 6' x 4' Stage Section
- 6' x 6' Qtr Circle Stage Section
- 6' x 6' Triangle Stage Section

We can build your stage at any height adding tiers and treads as required. Stage to be finished in new carpet or show floor with matching fascia.



Lecterns

Conical Lectern Fabric Covered

Perspex Lectern

Tri-Lite Lectern Polished

White or Black custom available



Conical Lectern



Tri-Lite Lectern



Perspex Lectern



DJ Booth

We stock DJ booths in black and white, these are finished in a buttonhole leatherette style.



Lighting Plinths





'it's all
white'

Make the day stylish and bright with our set, light and sound package - all in **white!**

BESPOKE - CALL US! **020 8670 5000**

WHITE:
SOUND SYSTEM • LIGHTING • SET AND STAGING

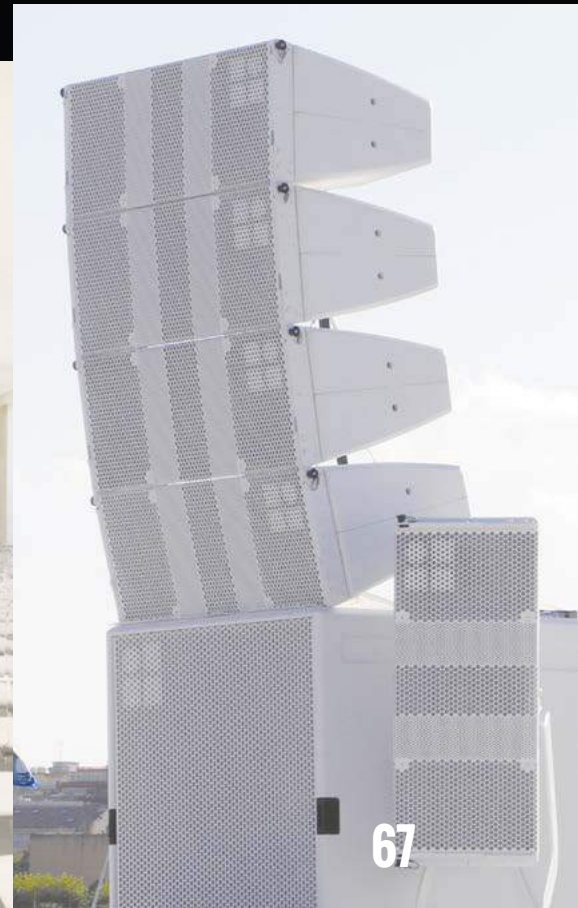



Speak: *easy*

YOUR CONFERENCE: CLEAN, SLICK AND CORPORATE

We can supply a 95" plasma set into a smart backdrop, lectern with stage and comfort monitor, small PA system with 4 microphones, switching equipment, labour and transport @ £3500



68



69

FLOOR FILLER

Our specially designed party package is suitable to entertain up to 200 guests...

- >> DJ with equipment
- >> Sound system
- >> DJ booth
- >> 4 moving lights on plinths
- >> Labour and transport

@ £2500

+ add > 12 wireless LED uplighters - £360

+ **Dance Floor** - call us for a quote!!



PR Live Ltd.

Unit 6 Windsor Centre Advance Road London SE27 9NT



Please see our website for full terms and conditions

© PR Live Ltd. All information correct at time of publication. May 2016

...and that's us.

PR LIVE
EVENT PRODUCTION & HIRE

2016

PR Live Ltd.
Unit 6, Windsor Centre
Advance Road
London
SE27 9NT

T: 0208 670 5000
E: hello@prlive.co
W: PRLive.co

